

SJ-Series Bevel Gearbox information

- 1: Models: SJ-T2, SJ-T4, SJ-T6, SJ-T7, SJ-T8, SJ-T10, SJ-T12, SJ-T16, SJ-T20, SJ-T25.
2. Gearing Type: Spiral Bevel Gear
3. Gear Ratio: 1:1, 1.5:1, 2:1, 3:1, 4:1, 5:1
4. Efficiency: 95%
8. Drive Shaft: 2 way, 3 way, 4 way
9. Noise Level: less than 80dB
10. Temperature Level: less than 50 °C
11. Work Temperature: -20°C~+80°C
12. Rotate Direction: clockwise, anti-clockwise

SJ-Series Bevel Gearbox Picture:



SJ-T2 Bevel Gearbox Specifications:

Ratio	1:1		1.5:1		2:1		2.5:1		3:1		4:1		5:1		
	r/min	N.m	KW	N.m	KW	N.m	KW	N.m	KW	N.m	KW	N.m	KW	N.m	KW
1450	11.6	1.79			12.1	0.94									
1150	11.7	1.43			12	0.74									
870	12.1	1.12			12	0.56									
580	12.1	0.747			11.9	0.37									
400	12.3	0.524			12.2	0.26									
300	12.3	0.396			11.9	0.19									
200	12.4	0.226			12.2	0.13									
100	12.7	0.136			11.2	0.06									
10	13.0	0.014			28.1	0.015									

SJ-T4 Bevel Gearbox Specifications:

Ratio	1:1		1.5:1		2:1		2.5:1		3:1		4:1		5:1		
	r/min	N.m	KW	N.m	KW	N.m	KW	N.m	KW	N.m	KW	N.m	KW	N.m	KW
1450	31.9	4.94			42.8	3.32									
1150	34.1	4.19			43.4	2.67									
870	37.2	3.46			43.8	2.04									
580	39.5	2.45			44.4	1.38									
400	40.2	1.72			45.1	0.96									
300	40.5	1.30			45.5	0.73									
200	41.2	0.88			46.1	0.49									
100	41.9	0.448			46.6	0.25									
10	43.0	0.046			48.5	0.026									

SJ-T6 Bevel Gearbox Specifications:

Ratio	1:1		1.5:1		2:1		2.5:1		3:1		4:1		5:1	
	r/min	N.m	KW	N.m	KW	N.m	KW	N.m	KW	N.m	KW	N.m	KW	N.m
1450	96.0	14.9	117	12.1	42.8	3.32	96.2	5.97	93.6	4.48	80.6	2.12	52.0	0.02
1150	103	12.7	122	9.96	43.4	2.67	97.2	4.78	94.8	3.88	81.5	2.50	52.5	1.61
870	113	10.5	123	7.66	43.8	2.04	99.0	3.68	95.9	2.97	82.4	1.92	53.2	1.29
580	119	7.35	126	5.23	44.4	1.38	100.0	2.48	97.6	2.02	84.1	1.30	54.2	0.99
400	122	5.20	128	3.66	45.1	0.96	100.9	1.73	99.0	1.41	85.1	0.91	54.9	0.67
300	123	3.93	129	2.77	45.5	0.73	102.9	1.32	100	1.07	86.1	0.69	55.5	0.47
200	124	2.66	131	1.87	46.1	0.49	103.9	0.888	100	0.71	86.0	0.46	55.4	0.36
100	127	1.36	134	0.957	46.6	0.25	104.9	0.448	102	0.36	87.7	0.23	56.5	0.24
10	132	0.141	139	0.099	48.5	0.026	107.8	0.046	104	0.04	89.3	0.02	57.6	0.12

SJ-T7 Bevel Gearbox Specifications:

Ratio	1:1		1.5:1		2:1		2.5:1		3:1		4:1		5:1	
	r/min	N.m	KW	N.m	KW	N.m	KW	N.m	KW	N.m	KW	N.m	KW	N.m
1450	142	22.0	145	15.0	137	10.6	113	6.99	105	5.42	93.4	3.62	57.4	1.78

1150	150	18.4	147	12.0	139	8.55	115	5.64	106	4.34	94.3	2.90	58.0	1.43
870	164	15.2	150	9.30	141	6.56	116	4.30	108	3.34	95.5	2.23	59.0	1.10
580	184	11.4	153	6.32	144	4.47	118	2.92	109	2.25	96.9	1.50	59.6	0.74
400	195	8.34	155	4.41	146	3.12	120	2.05	111	1.58	98.7	1.05	60.7	0.52
300	198	6.35	157	3.35	148	2.37	121	1.55	111	1.18	98.3	0.79	60.4	0.39
200	201	4.30	160	2.28	149	1.59	123	1.05	113	0.803	101	0.54	61.7	0.26
100	206	2.20	163	1.16	152	0.812	123	0.528	115	0.409	101	0.27	62.9	0.13
10	214	0.228	169	0.12	157	0.084	126	0.054	118	0.42	101	0.03	64.5	0.01

SJ-T8 Bevel Gearbox Specifications:

Ratio	1:1		1.5:1		2:1		2.5:1		3:1		4:1		5:1	
r/min	N.m	KW	N.m	KW	N.m	KW	N.m	KW	N.m	KW	N.m	KW	N.m	KW
1450	294	45.6	185	19.1	42.8	3.32	184	11.4	159	8.20	124	4.8	68.7	2.13
1150	305	37.5	188	15.4	43.4	2.67	185	9.11	160	6.55	125	3.83	69.2	1.70
870	312	29.0	191	11.8	43.8	2.04	188	7.00	163	5.04	127	2.95	70.4	1.31
580	319	19.8	197	8.14	44.4	1.38	192	4.76	166	3.42	129	2.00	71.7	0.89
400	326	14.0	200	5.70	45.1	0.96	195	3.34	168	2.39	131	1.40	72.6	0.62
300	331	10.6	203	4.34	45.5	0.73	197	2.53	169	1.80	131	1.05	72.9	0.47
200	338	7.2	204	2.91	46.1	0.49	200	1.710	171	1.22	134	0.71	74.1	0.32
100	346	3.7	210	1.49	46.6	0.25	203	0.867	173	0.618	135	0.36	75.1	0.16
10	361	0.386	218	0.155	48.5	0.026	208	0.089	179	0.064	140	0.04	77.8	0.02

SJ-T10 Bevel Gearbox Specifications:

Ratio	1:1		1.5:1		2:1		2.5:1		3:1		4:1		5:1	
r/min	N.m	KW	N.m	KW	N.m	KW	N.m	KW	N.m	KW	N.m	KW	N.m	KW
1450	421	65.3	374	38.7	305	23.6	293	18.2	270	14.0	241	9.35	136	4.21
1150	453	55.7	380	31.2	309	19.0	298	14.7	275	11.3	246	7.54	138	3.39
870	479	44.6	389	24.1	315	14.6	302	11.2	279	8.66	249	5.78	140	2.60
580	493	30.6	396	16.4	322	10.0	310	7.68	285	5.89	254	3.93	143	1.77
400	504	21.5	406	11.6	328	7.02	315	5.38	288	4.11	257	2.74	144	1.23
300	513	16.4	411	8.78	332	5.33	317	4.06	291	3.11	259	2.08	146	0.93
200	521	11.1	417	5.95	338	3.61	321	2.75	294	2.10	262	1.40	148	0.63
100	535	5.72	426	3.04	344	1.84	326	1.40	300	1.07	267	0.71	150	0.32
10	561	0.5999	443	0.316	357	0.191	336	0.144	308	0.11	275	0.07	155	0.03

SJ-T12 Bevel Gearbox Specifications:

Ratio	1:1		1.5:1		2:1		2.5:1		3:1		4:1		5:1	
r/min	N.m	KW	N.m	KW	N.m	KW	N.m	KW	N.m	KW	N.m	KW	N.m	KW
1450	619	96.0	564	58.3	516	40.0	507	31.4	458	23.6	434	16.8	296	9.18
1150	665	81.1	601	49.2	516	31.7	514	25.3	464	19.0	441	13.5	301	7.39
870	726	67.5	656	40.7	516	24.0	523	19.5	469	14.6	448	10.4	305	5.68
580	802	49.7	699	28.9	524	16.3	535	13.3	480	9.92	456	70.7	311	3.86
400	821	35.1	711	20.3	538	11.5	545	9.32	490	6.98	465	4.97	318	2.72
300	835	26.8	724	15.5	543	8.71	552	7.08	495	5.29	470	3.77	321	2.06
200	852	18.2	736	10.5	551	5.89	560	4.79	501	3.57	476	2.54	325	1.39
100	875	9.36	754	5.37	563	3.01	568	2.43	510	1.82	485	1.30	331	0.71

10	919	0.983	785	0.56	586	0.313	588	0.251	527	0.188	501	0.13	342	0.07
----	-----	-------	-----	------	-----	-------	-----	-------	-----	-------	-----	------	-----	------

SJ-T16 Bevel Gearbox Specifications

Ratio	1:1		1.5:1		2:1		2.5:1		3:1		4:1		5:1	
	r/min	N.m	KW	N.m	KW	N.m	KW	N.m	KW	N.m	KW	N.m	KW	N.m
1450	1019	163			921	73.7			904	48.2	850	34.3	814	26.3
1150	1098	139			938	59.5			920	38.9	865	27.7	828	21.2
870	1186	114			958	46			940	30.1	884	21.4	847	16.4
580	1343	85.9			980	31.3			960	20.4	902	14.6	864	11.2
400	1499	66.1			1000	22			978	14.4	919	10.2	881	7.85
300	1637	54.1			1009	16.7			990	10.9	930	7.8	891	5.96
200	1784	39.3			1029	11.3			1005	7.38	944	5.3	905	4.03
100	1842	20.3			1058	5.84			1038	3.82	976	2.7	935	2.08
10	1940	2.14			1098	0.605			1076	0.4	1011	0.3	969	0.22

SJ-T20 Bevel Gearbox Specifications

Ratio	1:1		1.5:1		2:1		2.5:1		3:1		4:1		5:1	
	r/min	N.m	KW	N.m	KW	N.m	KW	N.m	KW	N.m	KW	N.m	KW	N.m
1450					1578	126			1529	82.3	1452	58.7	1391	44.9
1150	1842	234			1607	102			1561	66.6	1483	47.5	1420	36.4
870	2009	193			1646	79			1598	51.6	1518	36.8	1454	28.2
580	2274	145			1695	54.2			1644	35.4	1562	25.2	1496	19.3
400	2538	112			1725	38			1672	24.8	1588	17.7	1521	13.6
300	2744	90.8			1754	29			1701	18.9	1616	13.5	1548	10.3
200	3125	69			1784	19.7			1733	12.9	1646	9.17	1577	7.03
100	3206	35.3			1833	101			1777	6.6	1688	4.7	1617	3.6
10	3205	3.35			1921	1.06			1865	0.69	1772	0.49	1697	0.38

SJ-T25 Bevel Gearbox Specifications

Ratio	1:1		1.5:1		2:1		2.5:1		3:1		4:1		5:1	
	r/min	N.m	KW	N.m	KW	N.m	KW	N.m	KW	N.m	KW	N.m	KW	N.m
1450											2798	113	2631	85
1150					3146	199			2935	158	2892	92.6	2771	71
870	3489	335			3224	155			3045	130	2978	72.2	2853	55.3
580	3940	252			3332	107			3135	101	3084	49.8	2954	38.2
400	4410	195			3420	75.4			3246	69.9	3151	35.1	3018	26.9
300	4792	159			3479	57.5			3317	49.3	3204	26.8	3069	20.5
200	5390	119			3557	39.2			3372	37.6	3276	18.2	3138	14
100	5439	60			3646	20.1			3449	25.6	3360	9.36	3218	7.17
10	5713	6.3			3822	2.11			3537	13.1	3527	0.98	3378	0.75

SJ-T25 Bevel Gearbox Ordering Information:

SJ - T25 - 1:1 - I-LR-O - A
1 2 3 4 5

1: Bevel Gearbox Brand

SJ: "SIJIE" brand bevel gearbox

2: Gearbox base NO.

T2, T4, T6, T7, T8, T10, T12, T16, T20, T25.

3: Gear Ratio

1:1, 1.5:1, 2:1, 3:1, 4:1, 5:1

4: Transmission Directions Code

There are 42 type transmission directions code for customers selection, please check below I-LR(O) series, I-UD(O) series, U-LR(O) series, D-LR(O) series, I-I-LR(O) series, I-I-UD(O) series, U-D-LR(O) series transmission directions code.

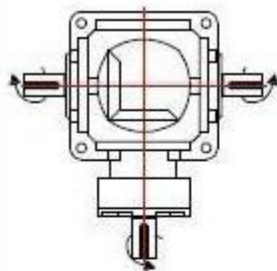

I-LR

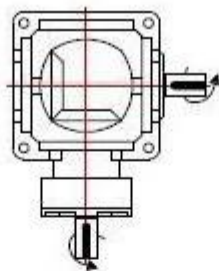

I-R

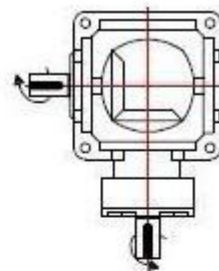

I-L

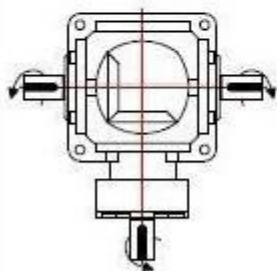

I-LR-0

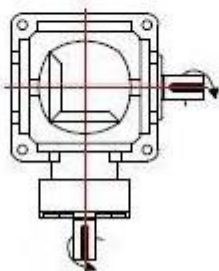

I-R-0

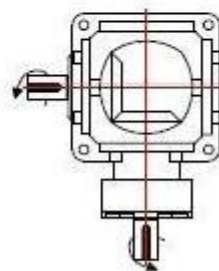

I-L-0

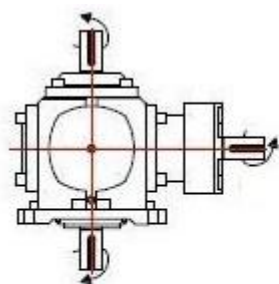

I-UD

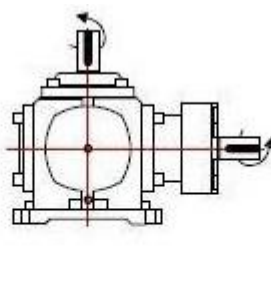

I-U

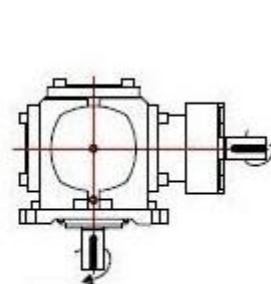

I-D

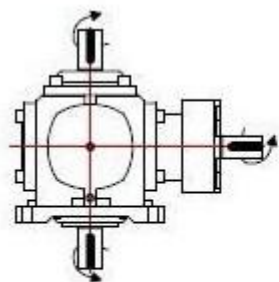

I-UD-0

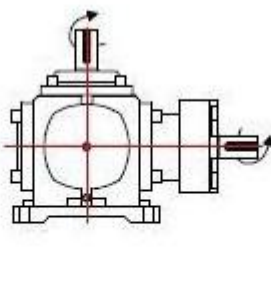

I-U-0

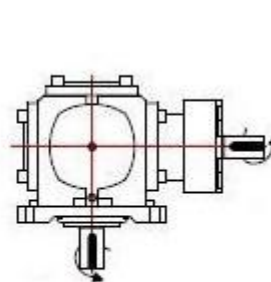

I-D-0

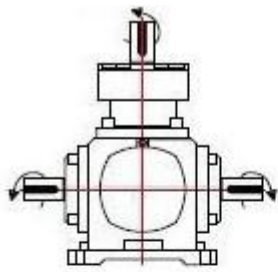

U-LR

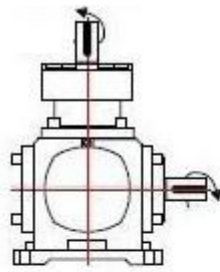

U-R

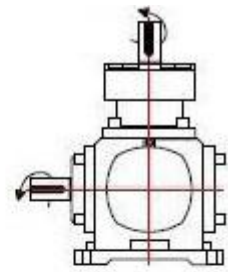

U-L

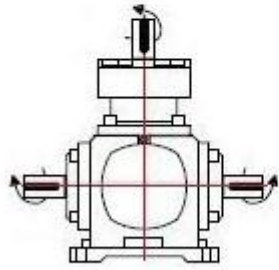

U-LR-0

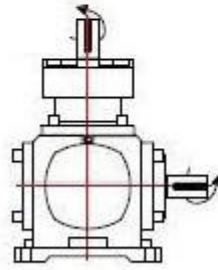

U-R-0

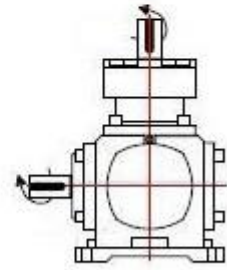

U-L-0

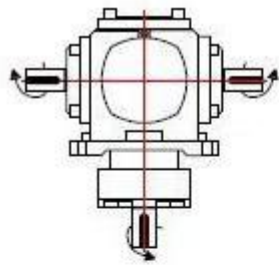

D-LR

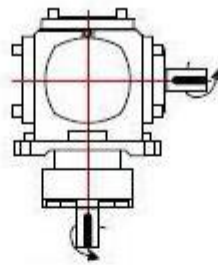

D-R

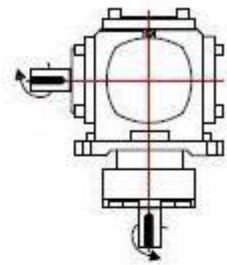

D-L

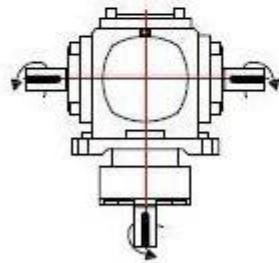

D-LR-0

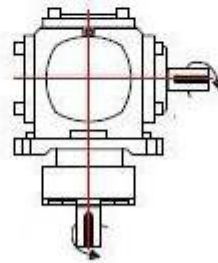

D-R-0

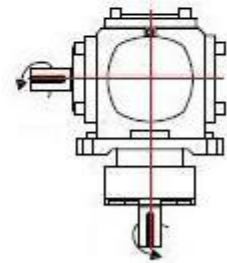

D-L-0

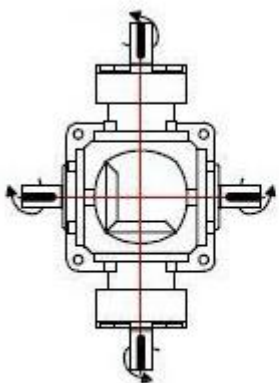

I-I-LR

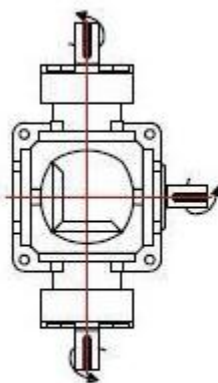

I-I-R

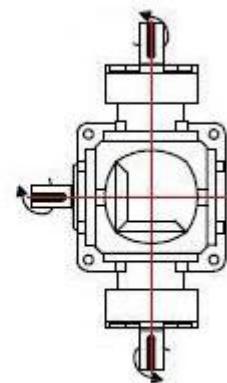

I-I-L

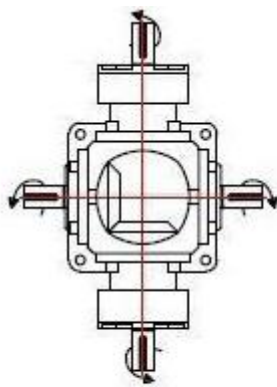

I-I-LR-0

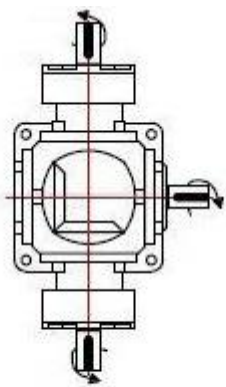

I-I-R-0

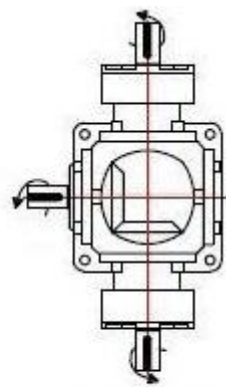

I-I-L-0

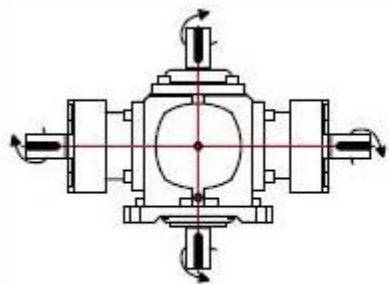

I-I-UD

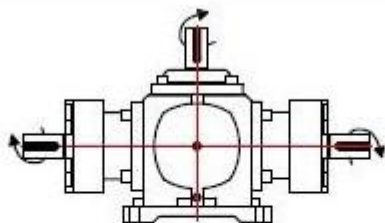

I-I-U

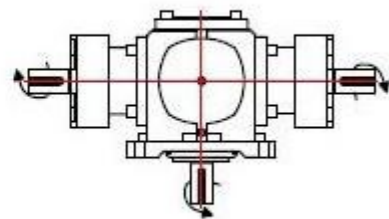

I-I-D

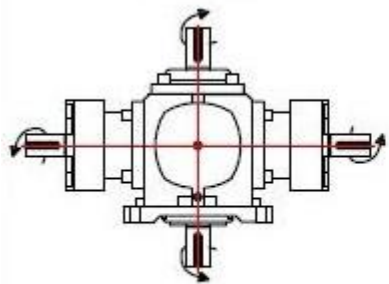

I-I-UD-0

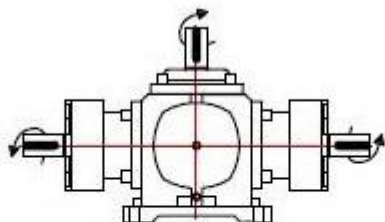

I-I-U-0

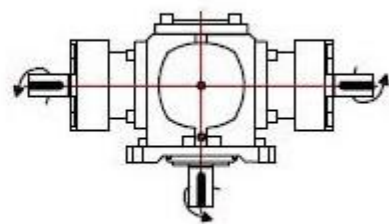

I-I-D-0

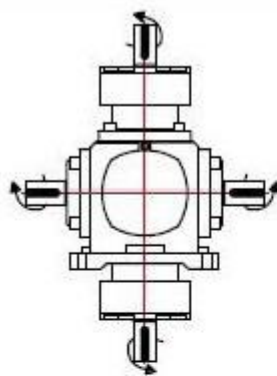

U-D-LR

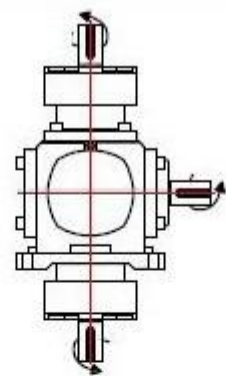

U-D-R

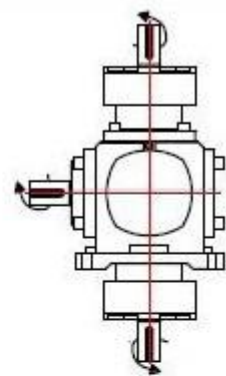

U-D-L

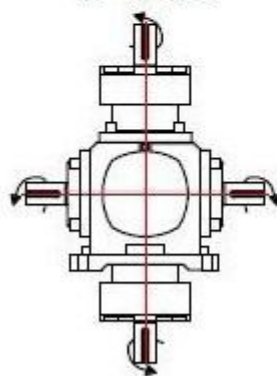

U-D-LR-0

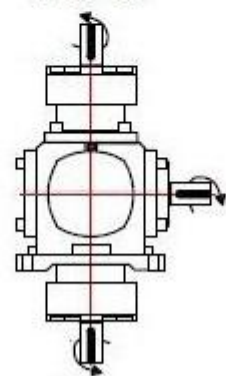

U-D-R-0

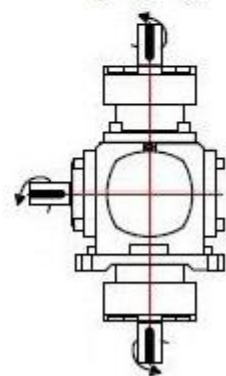







U-D-L-0

5: Mounting Position

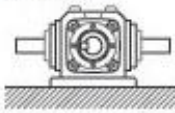
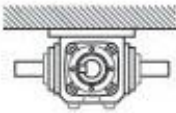
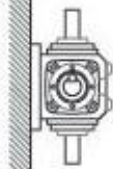
A: Horizontal Mounting Position

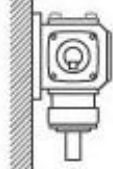
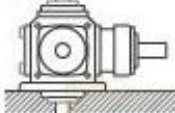
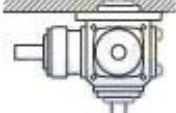
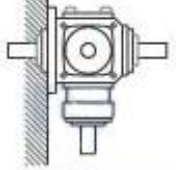
B: Over Hung Mounting Position

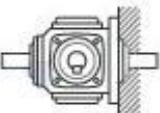
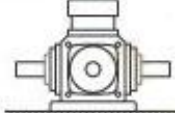
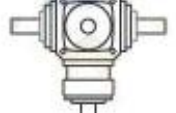
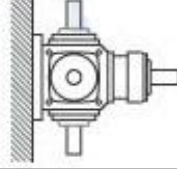
C: Side Wall Mounting Position

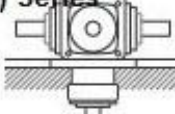
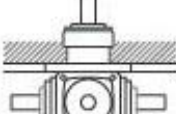
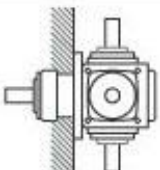
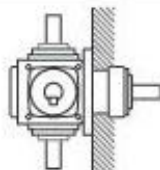
Horizontal	Over Hung	Side Wall		
I-LR(O) Series 				
I-UD(O) Series 				
U-LR(O) Series 				
D-LR(O) Series 				

SJ-T2 Bevel Gearbox Dimensions

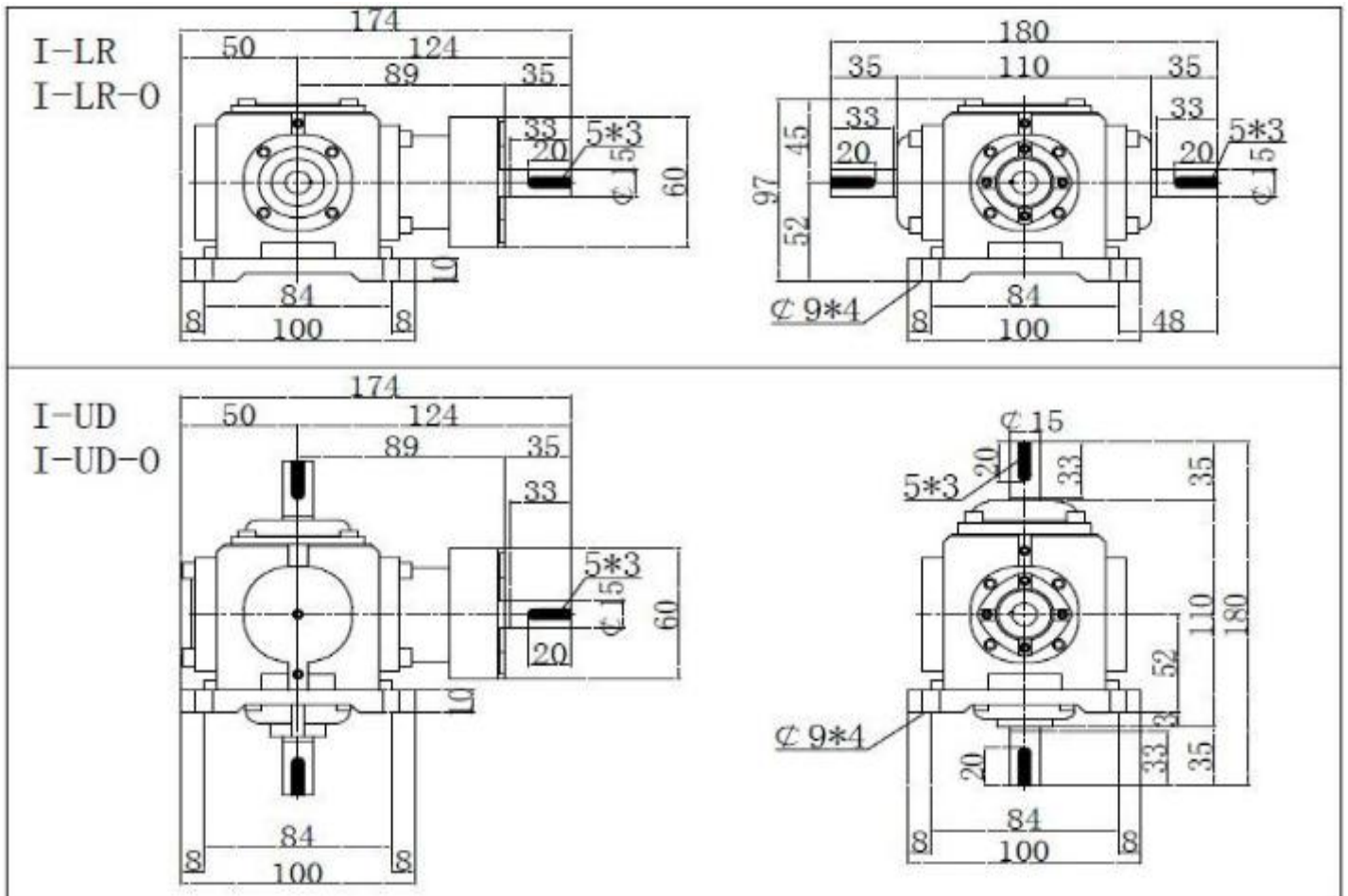

U-LR
U-LR-0

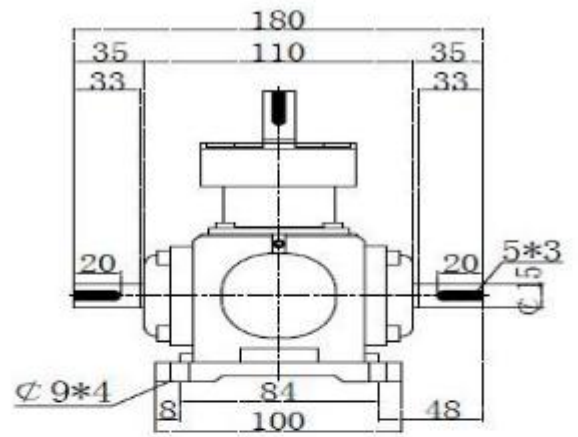
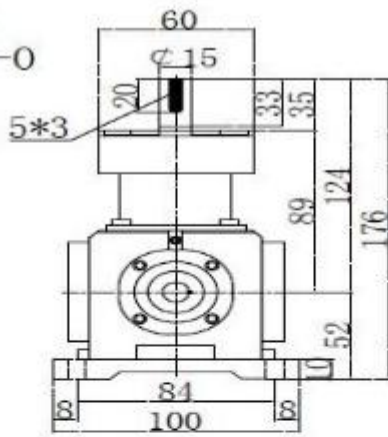

D-LR
D-LR-0

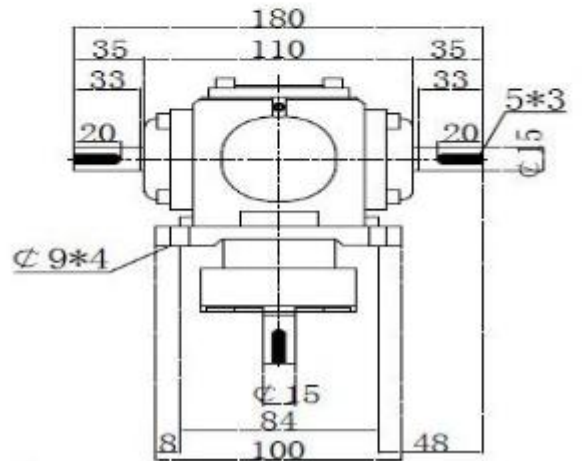
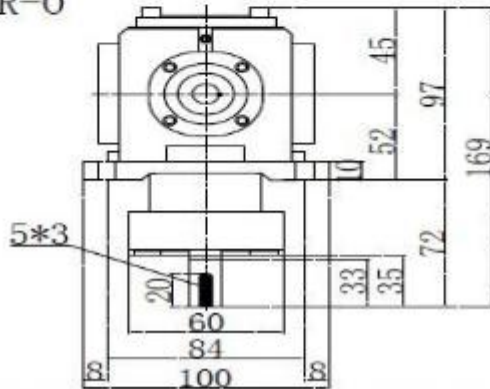

SJ-T4 Bevel Gearbox Dimensions

I-LR
I-LR-0

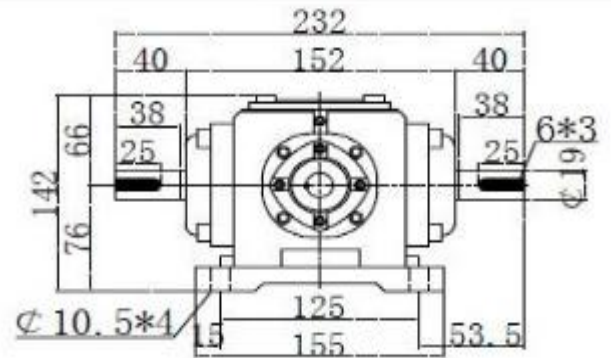
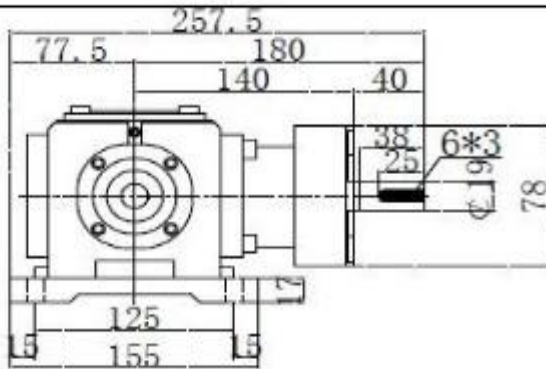

I-UD
I-UD-0

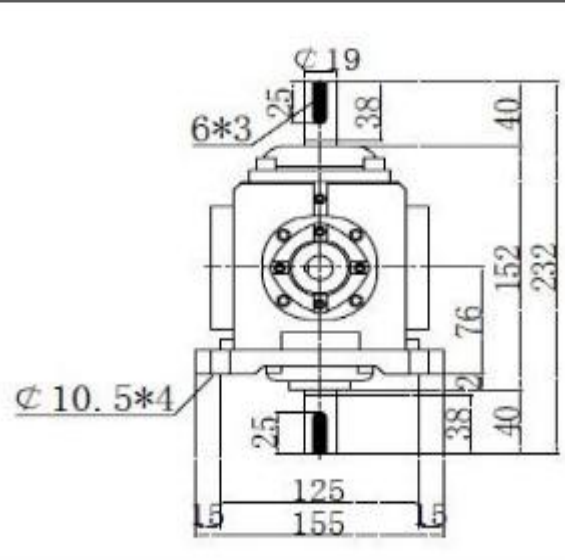
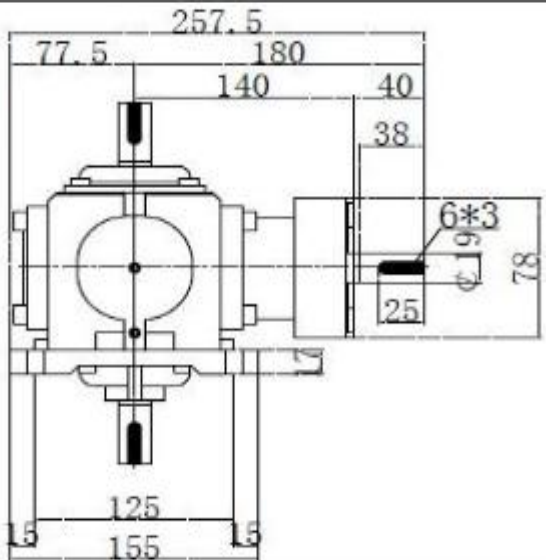

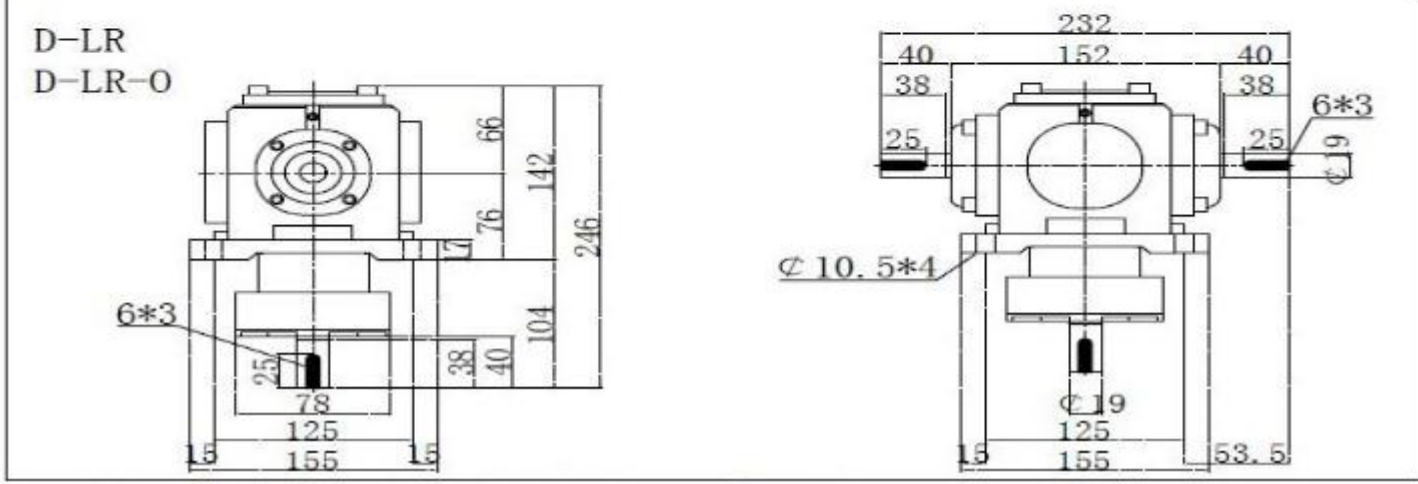
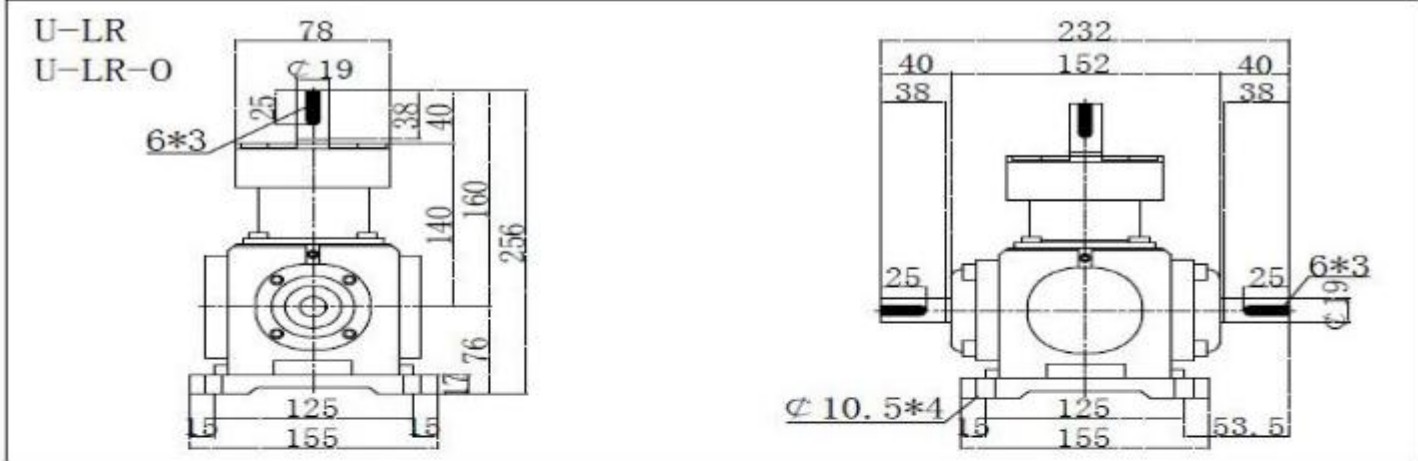

SJ-T6 Bevel Gearbox Dimensions

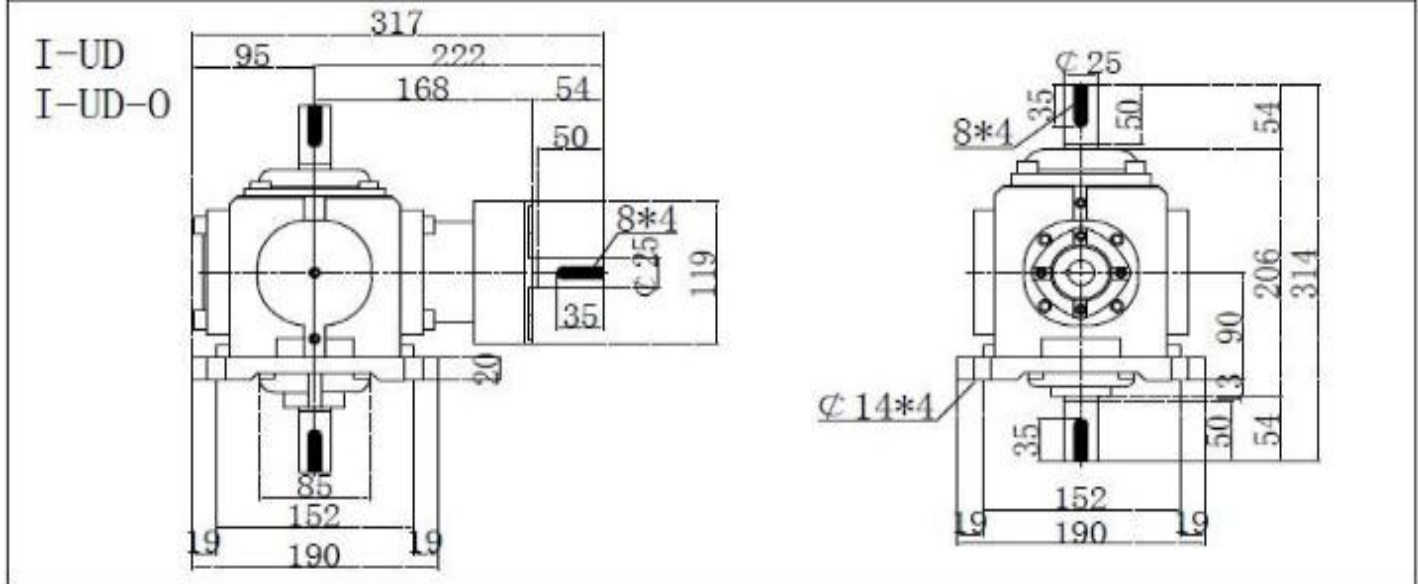
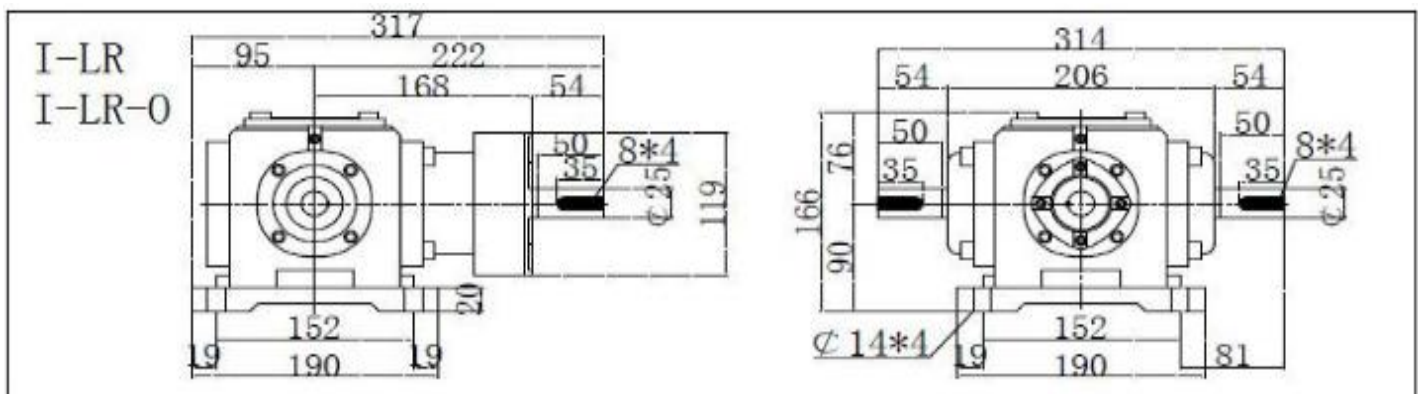

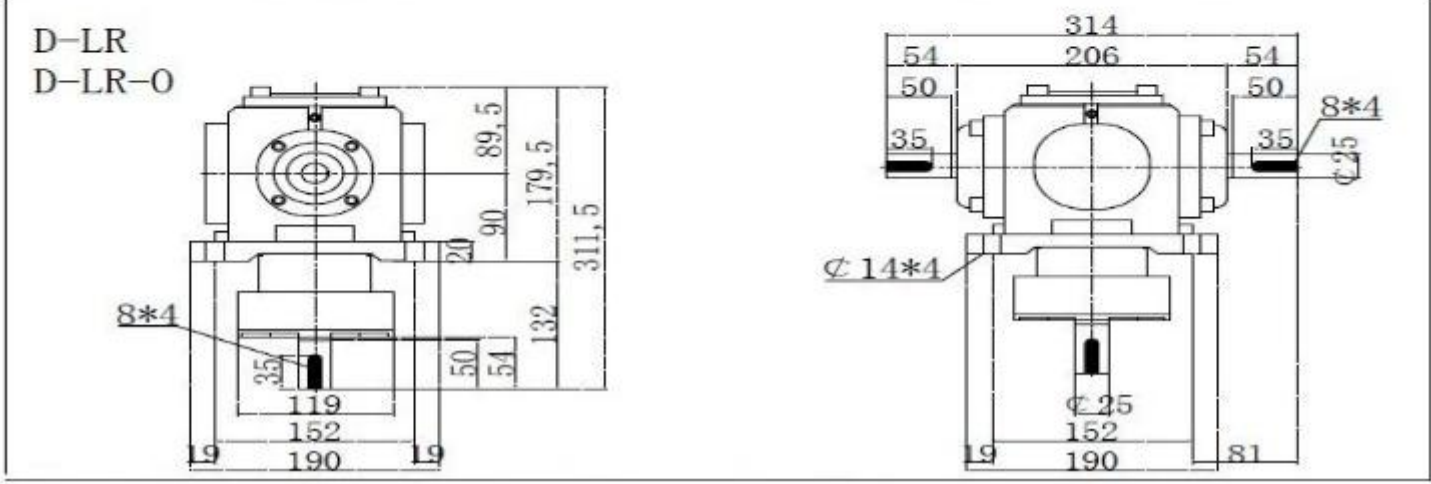
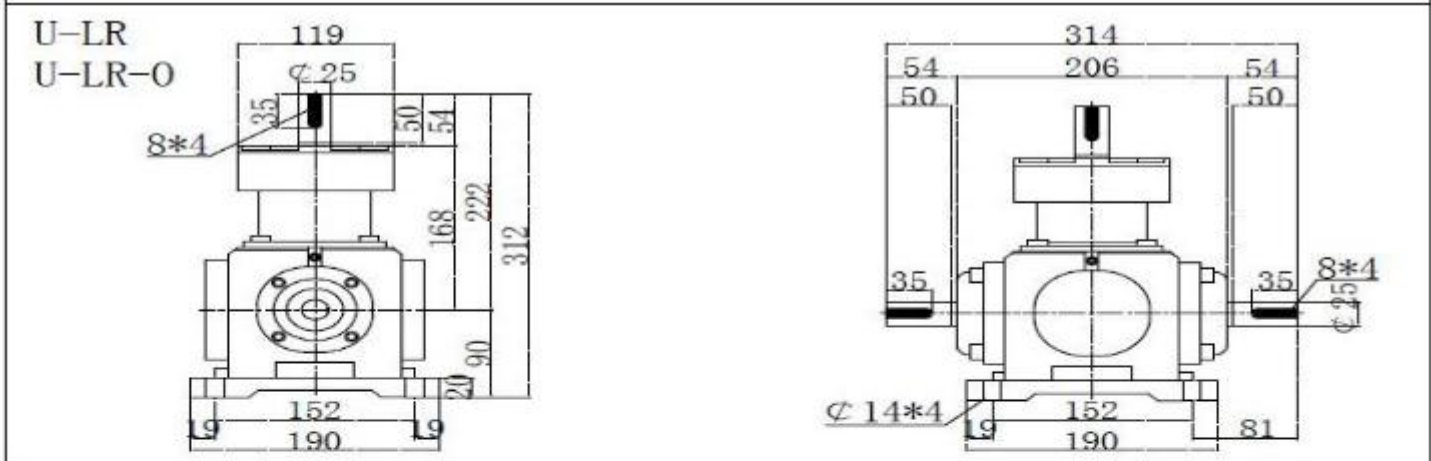

SJ-T7 Bevel Gearbox Dimensions

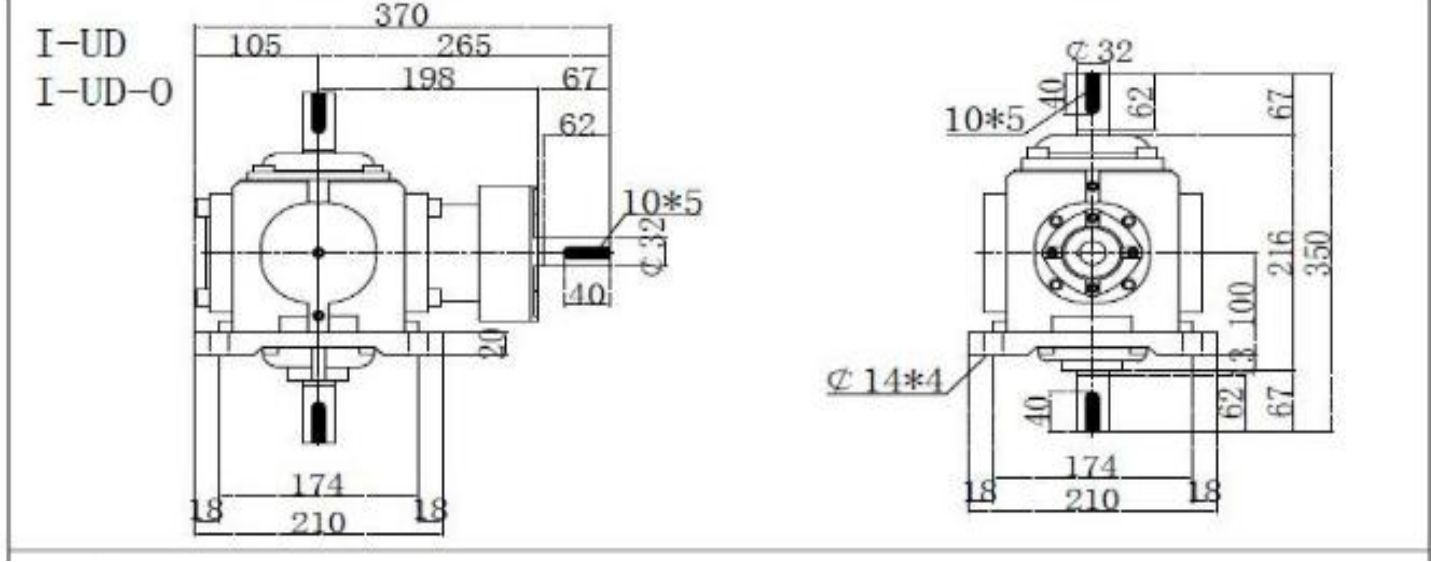
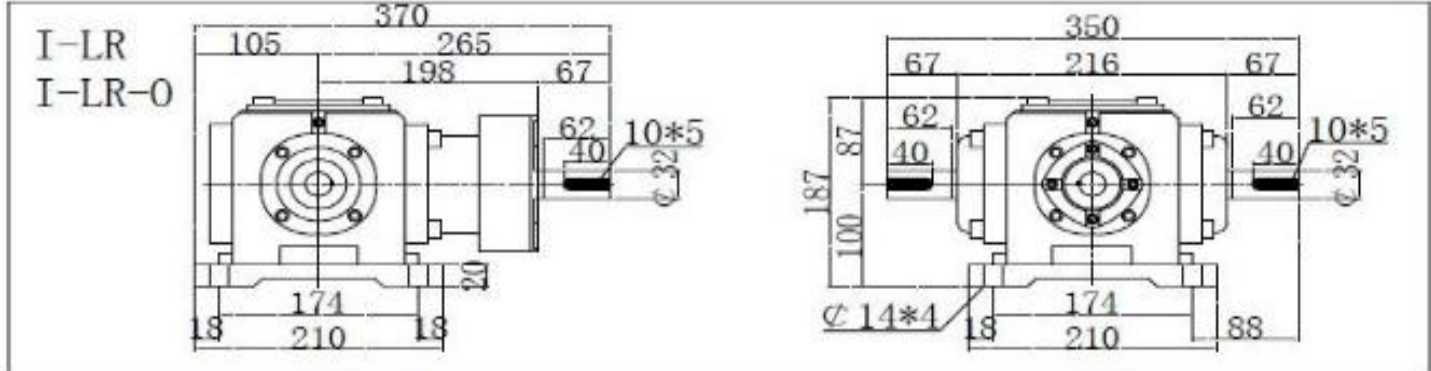

U-LR
U-LR-0

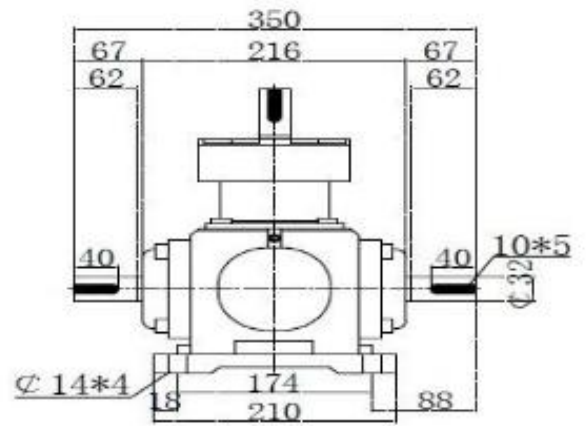
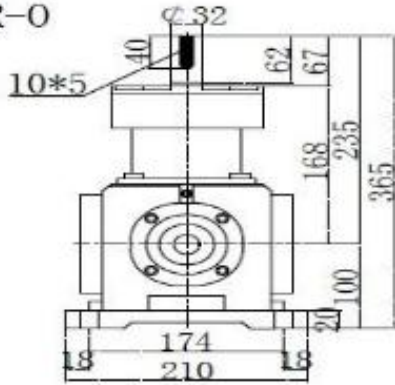

D-LR
D-LR-0

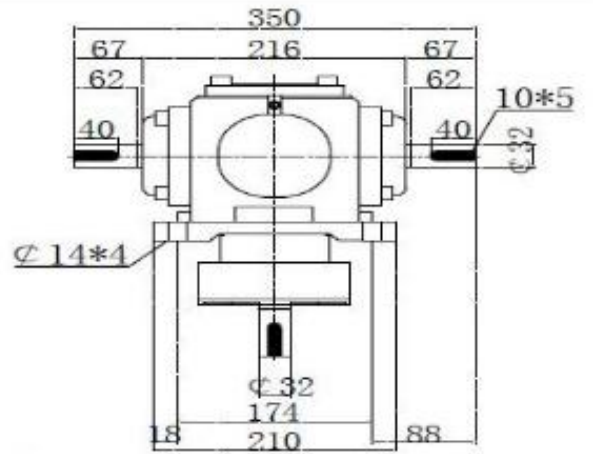
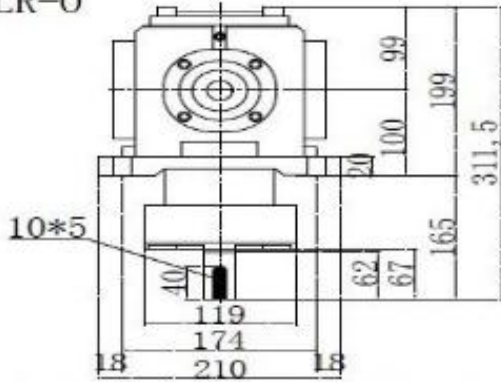

SJ-T8 Bevel Gearbox Dimensions

I-LR
I-LR-0

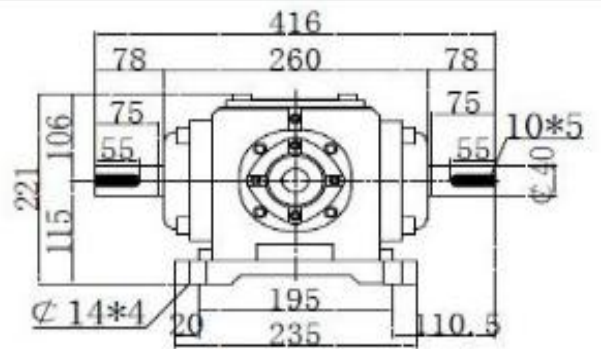
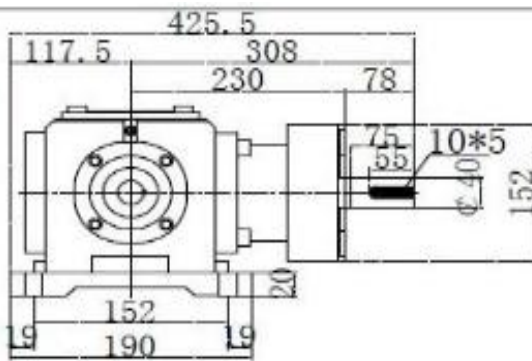

I-UD
I-UD-0

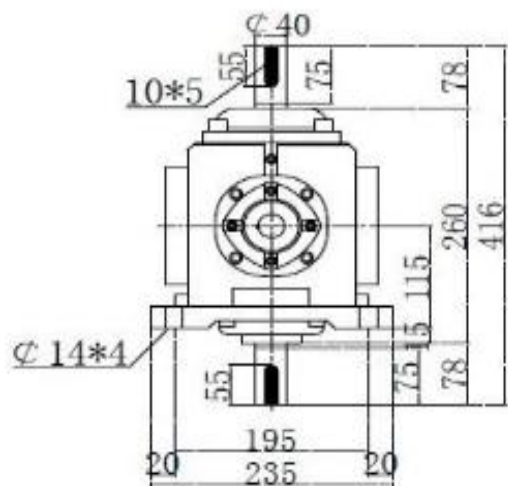
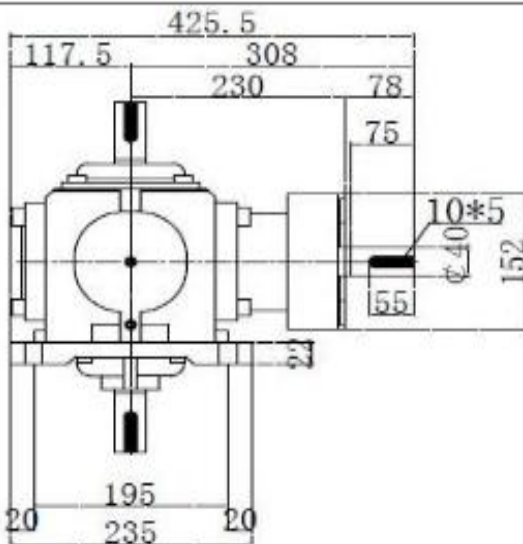

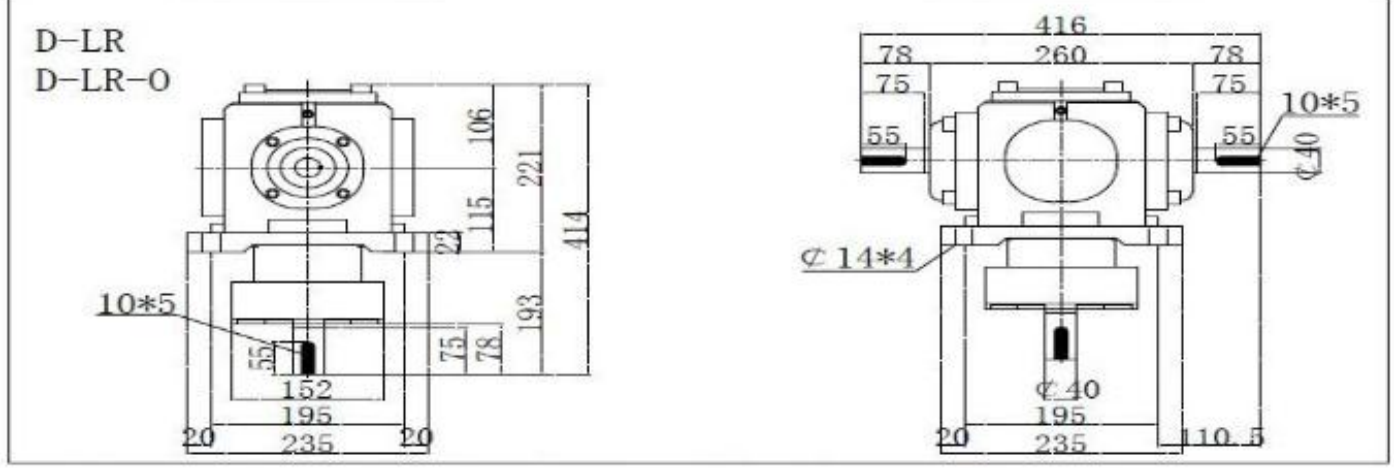
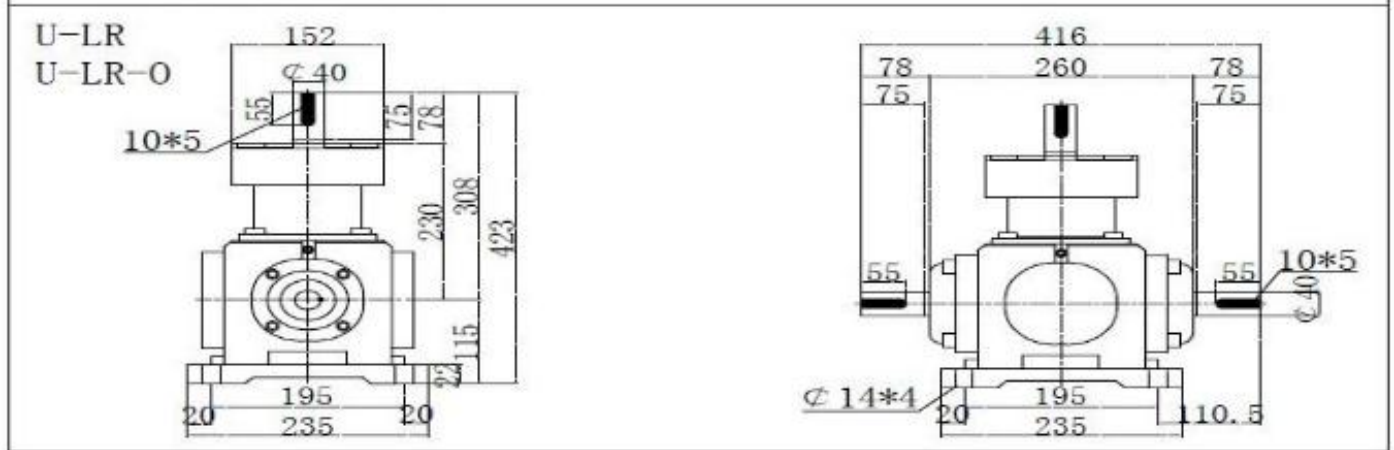

SJ-T10 Bevel Gearbox Dimensions

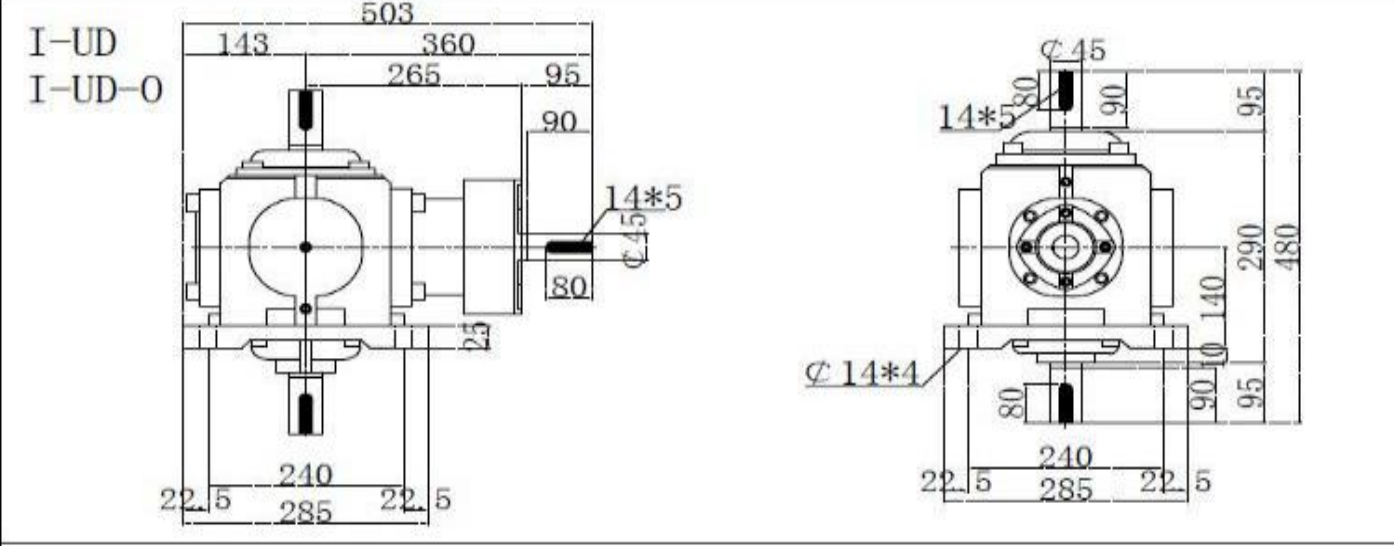
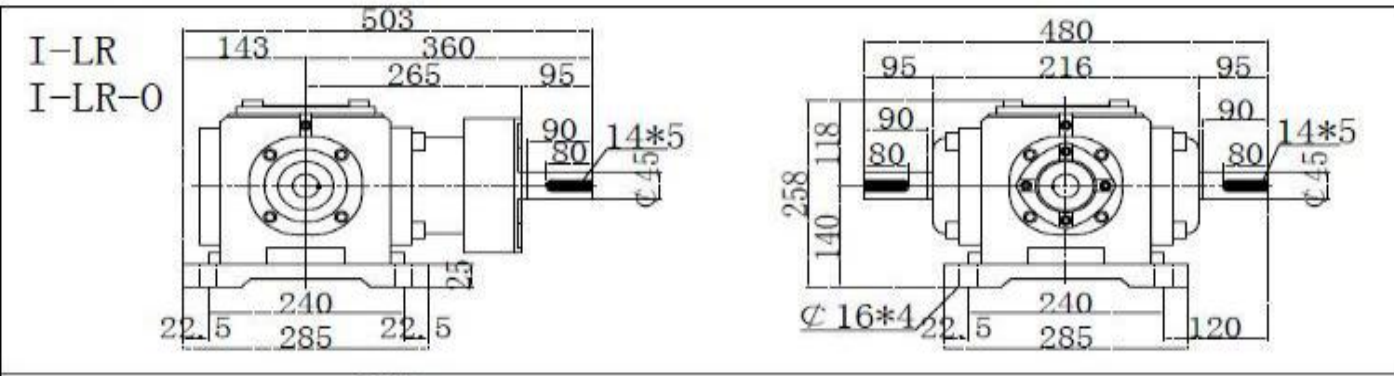

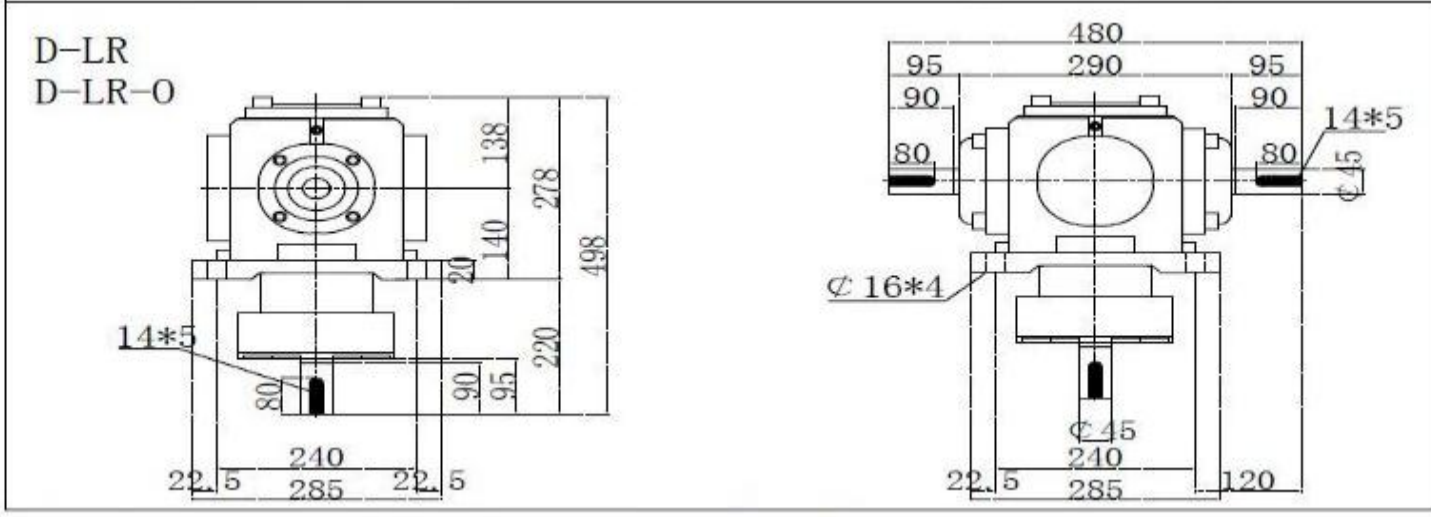
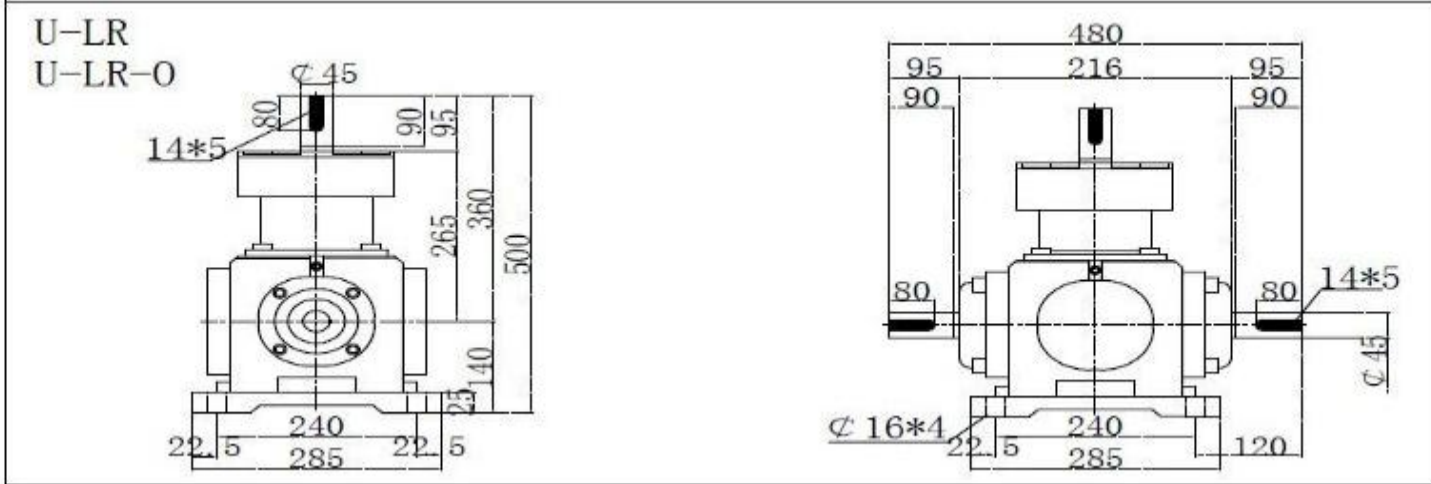

SJ-T12 Bevel Gearbox Dimensions

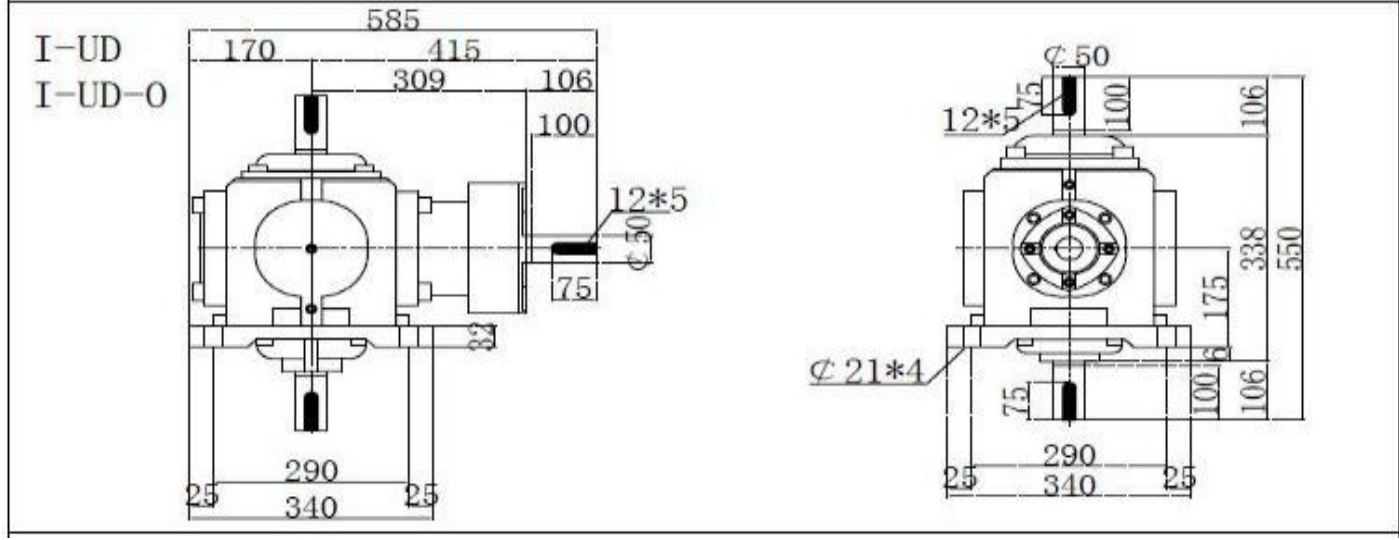
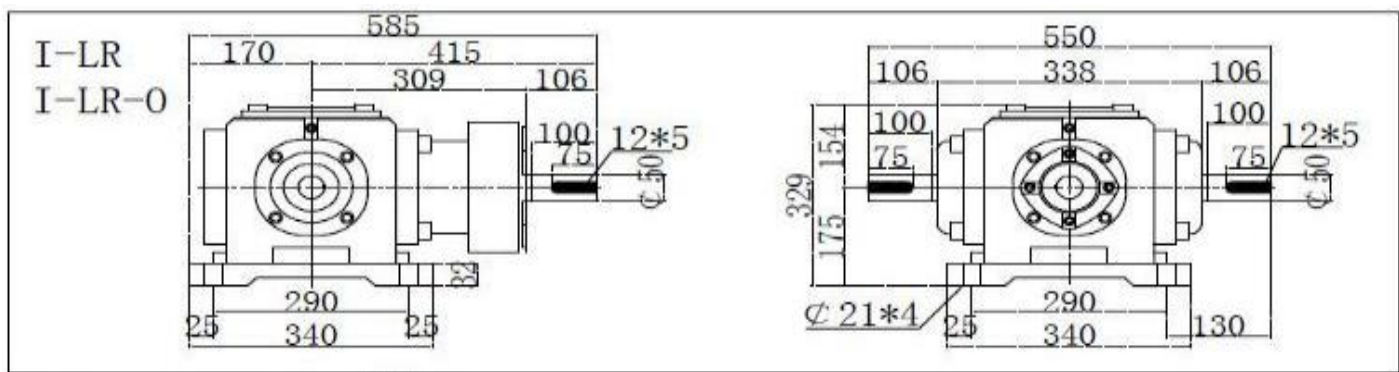

U-LR
U-LR-0

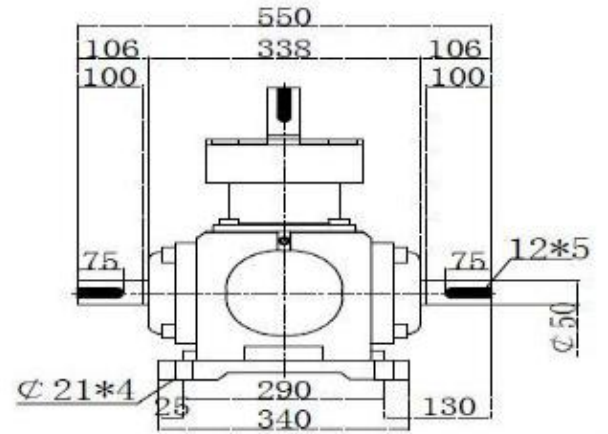
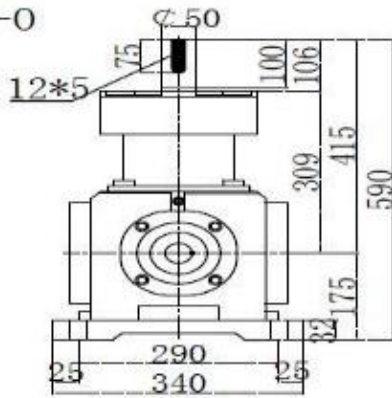

D-LR
D-LR-0

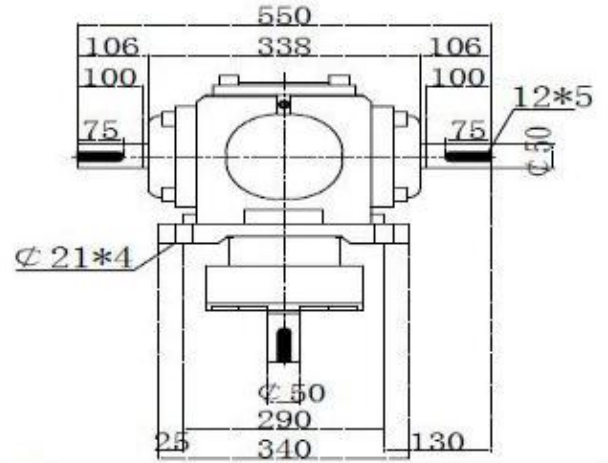
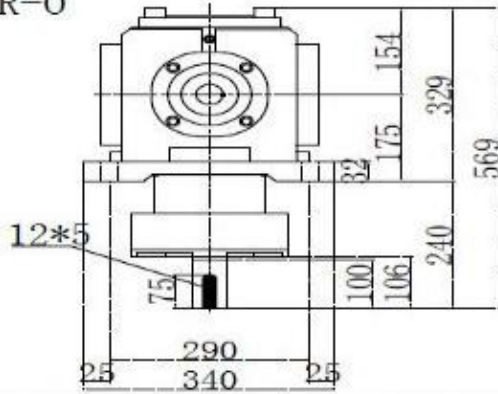

SJ-T16 Bevel Gearbox Dimensions

I-LR
I-LR-0

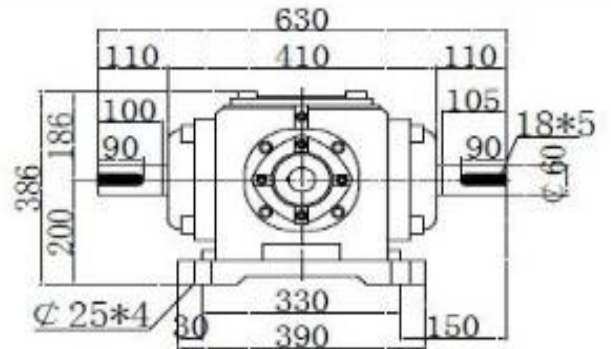
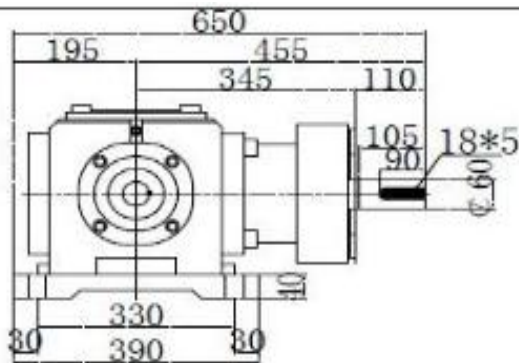

I-UD
I-UD-0

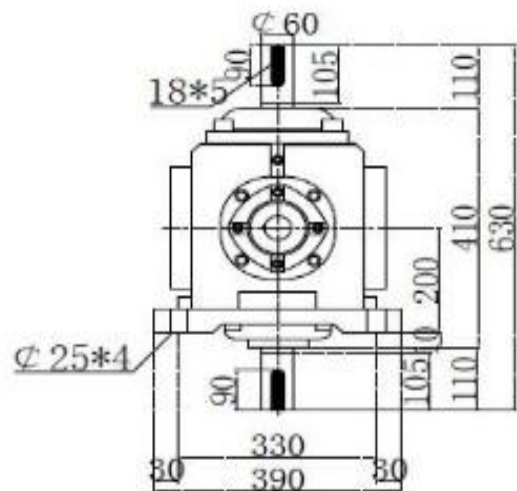
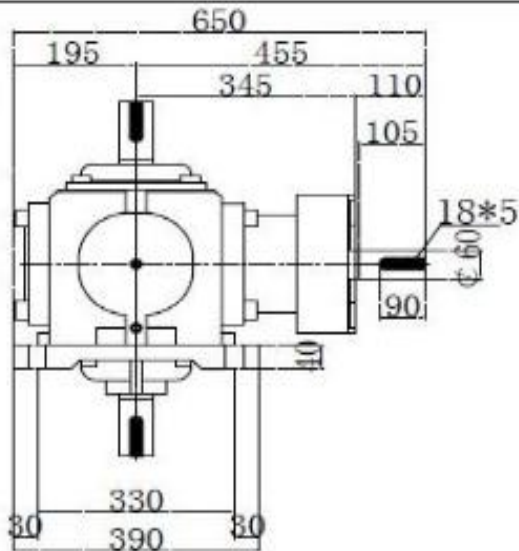

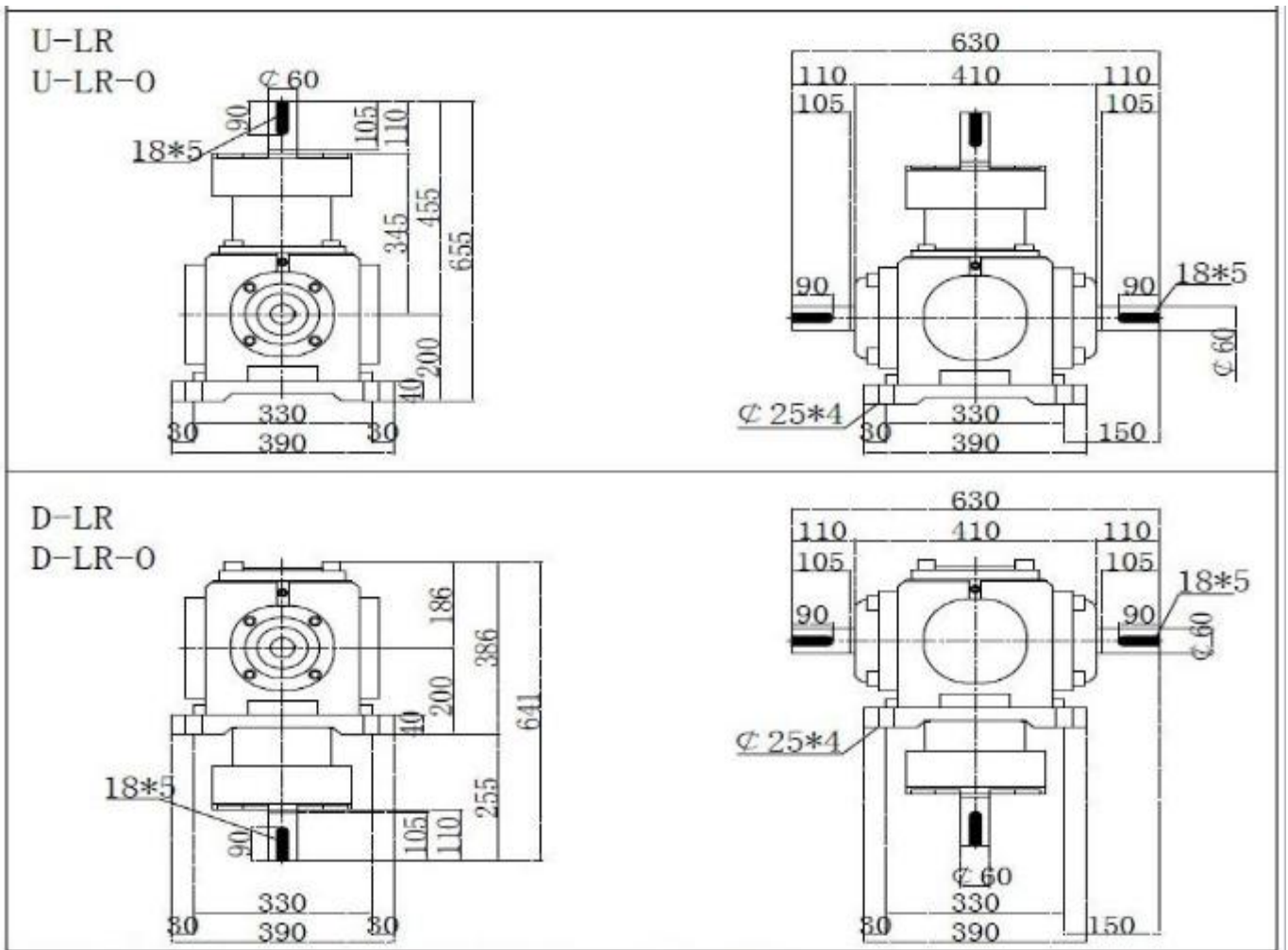

SJ-T20 Bevel Gearbox Dimensions

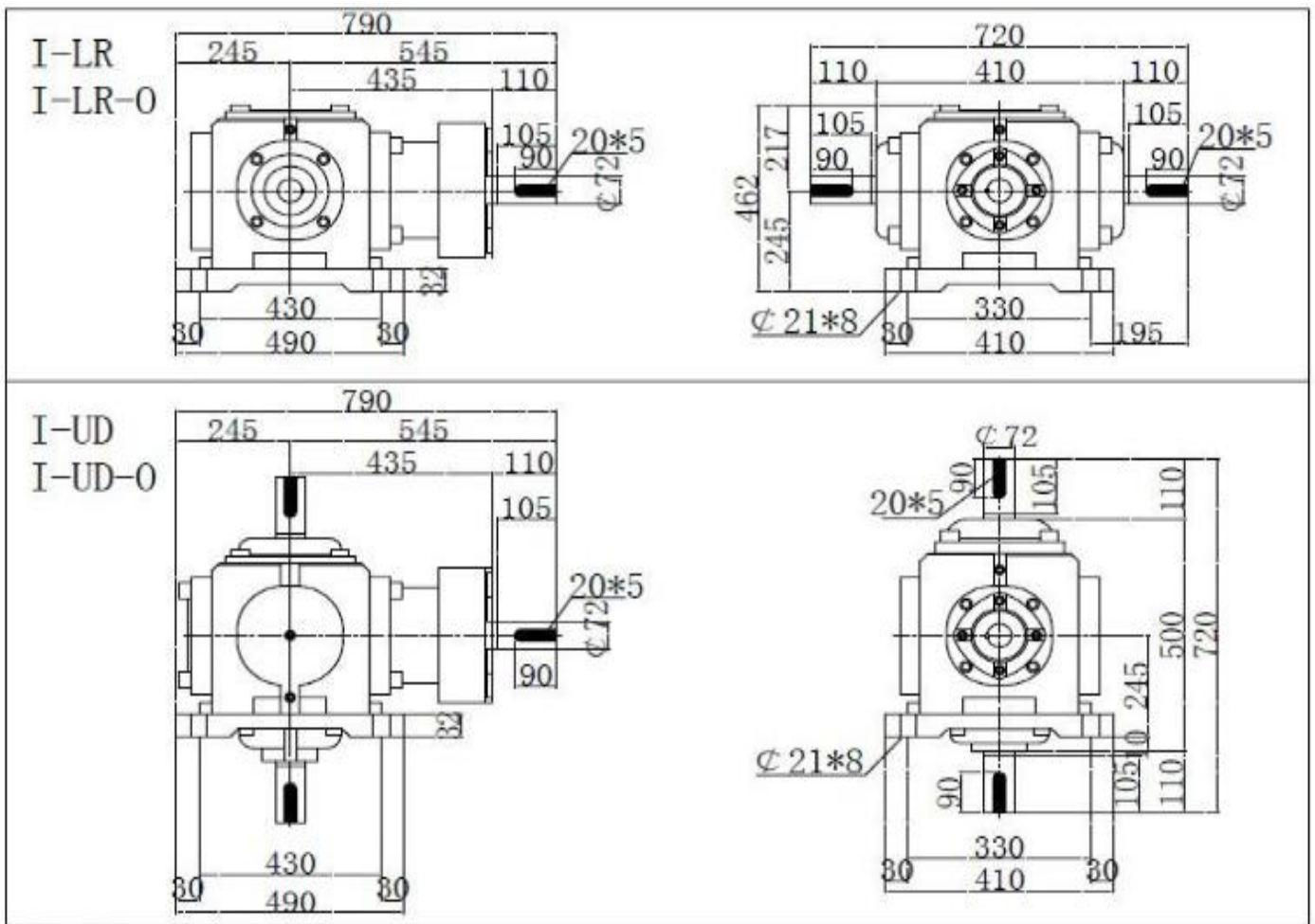

U-LR
U-LR-0

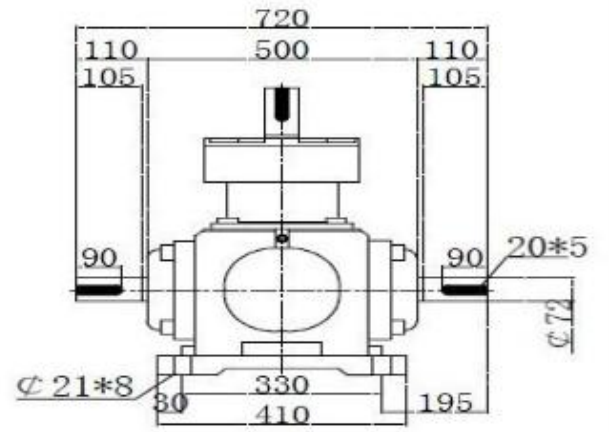
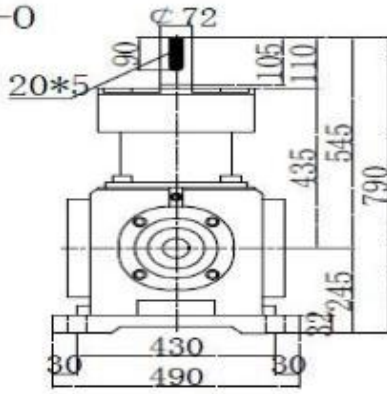

D-LR
D-LR-0

